



10pt touch open frame monitor with AG-coating and high brightness

ProLite TF2234MC uses PCAP touch technology and is built into an eye catching bezel with edge-to-edge glass. Featuring IPS LCD Screen technology, it offers exceptional colour performance and wide viewing angles. The higher brightness ensures crispy and clear images, even in a bright environment. In addition to the superb image quality, the screen is suitable for demanding environments. It comes with a rugged bezel and IP65 rating, meaning the monitor is dust and water resistant from the front. The Anti Glare coating helps to avoid issues with reflections and external light sources affecting colour reproduction, contrast and sharpness. ProLite TF2234MC is the ideal screen for the kiosk integrators and a solution for Interactive Digital Signage, Instore Retail and Interactive Presentations.



IPS

IPS technology offers higher contrast, darker blacks and much better viewing angles than standard TN technology. The screen will look good no matter what angle you look at it.

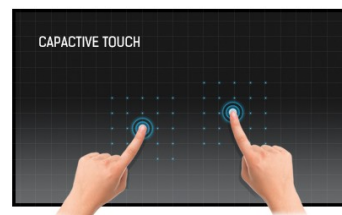

TOUCH TECHNOLOGY - CAPACITIVE

This technology uses a sensor-grid of micro-fine wires integrated into the glass that covers the screen. Touch is detected because electrical characteristics of the sensor grid change when human finger is placed on the glass. Thanks to the glass overlay this technology is highly durable, and the touch function remains unaffected even if the glass is scratched. It offers perfect picture performance and will work with human finger (also latex gloved) and stylus-pen.

1. DISPLAY CHARACTERISTICS

DIAGONAL	21.5"; 55cm
ASPECT RATIO	16 : 9
PANEL	IPS LED, AG coated glass
NATIVE RESOLUTION	Full HD 1080p, 1920 x 1080 (2.1 megapixel)
BRIGHTNESS	350 cd/m ² typical
BRIGHTNESS	290 cd/m ² with touch panel
CONTRAST	1 000 : 1 with touch panel
RESPONSE TIME	8 ms
VIEWING ZONE	horizontal/vertical: 178° / 178° ; right/left: 89° / 89° ; up/down: 89° / 89°
DISPLAY COLOUR	16.7 million
TOUCHTECHNOLOGY	projective capacitive, multi touch (10 compatible touch points - HID, supported only under Windows® 7/8/10), activated by finger
TOUCH POINTS	10
GLASS THICKNESS	1.5 mm
GLASS HARDNESS	6H minimum
LIGHT TRANSMITTANCE	83%%
DISPLAY AREA H X W	268.1 x 476.6 mm; 10.6" x 18.8"
PIXEL PITCH H X V	0.247 x 0.247 mm
HORIZONTAL SYNC	31.5 - 82.3 KHz
VERTICAL SYNC	56 - 75 Hz
SYNCHRONIZATION	Separate Sync
ANTI-GLARE COATING	yes

2. INTERFACES & CONNECTORS

ANALOG INPUT CONNECTOR	VGA
DIGITAL INPUT CONNECTOR	DVI
CONTROLS	USB (touch)

3. FEATURES

PLUG & PLAY	VESA DDC2B™
CONTROLS	On-Screen-Display in 7 languages (DE, EN, ES, FR, IT, JP, Chinese - traditional and simplified) and 5 front controls (Menu, Scroll up/ Brightness, Scroll down/ Contrast, Select/ Auto, Power)
USER CONTROLS	contrast, brightness, auto adjust, H.position, V.position, H.size, phase, OSD H.position, OSD V.position, OSD timeout, reset, input select, OSD language, colour temperature
REGULATIONS	CE, TÜV-Bauart, cULus, CU, VCCI
VESA MOUNTING	100 x 100 mm
COLOUR	Black
ORIENTATION	Landscape / portrait / face-up

4. ACCESSORIES

DRIVER

multi-touch: Windows7/8/10 (HID compliant), single-touch: Vista, XP, 9X, 2000, CE, NT4, Linux, Mac (OSX)

INCLUDED ACCESSORIES

AC adapter, power cable, VGA signal cable, DVI signal cable, USB cable, Touch Panel Driver Disk (CD-ROM), brackets, quick start guide, safety guide, L-brackets

OPTIONAL ACCESSORIES

remote control OSD key

5. POWER MANAGEMENT

POWER SUPPLY

DC 12V

POWER SUPPLY UNIT

external

POWER USAGE

27 W typical; max. 2 W in Power management mode

POWER MANAGEMENT

VESA DPMS

6. DIMENSIONS & WEIGHT

DIMENSIONS W X H X D

517.5 x 313.5 x 46 mm

WEIGHT

4.4 kg

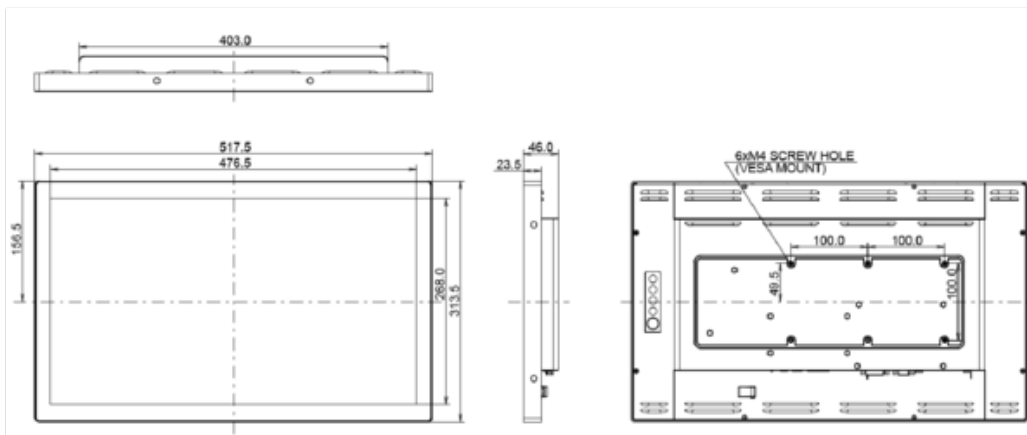

All trademarks and registered trademarks acknowledged. E & O E. Specification subject to change without notice. All LCD's comply with ISO-9241-307:2008 in connection with pixel defects.